

# HYG320C06LA1S

## 60V Complementary MOSFET

### Feature

#### N- Channel

V<sub>ds</sub> = 60V

7 A (V<sub>gs</sub>= 10V)

19 mΩ (V<sub>gs</sub>= 10V)

24 mΩ (V<sub>gs</sub>= 4.5V)

#### P - Channel

V<sub>ds</sub> = -60V

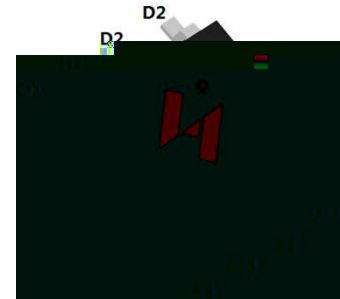
-4.2 A (V<sub>gs</sub>= -10V)

58 mΩ (V<sub>gs</sub>= -10V)

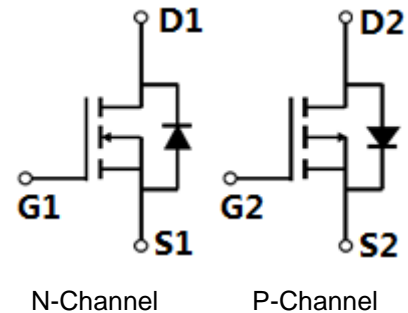
72 mΩ (V<sub>gs</sub>= -4.5V)

- 100% Avalanche Tested
- Reliable and Rugged
- Halogen Free and Green Devices Available (RoHS Compliant)

### Pin Description



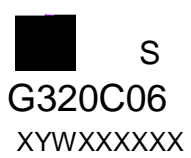
SOP8L



### Applications

- Synchronous Rectifiers
- H-bridge Motor Drive

### Ordering and Marking Information

	<p>Package Code S: SOP8L</p> <p>Date Code XYWXXXXXX</p>
---	---

Note: HUAYI lead-free products contain molding compounds/die attach materials and 100% matte tin plate Termination finish; which are fully compliant with RoHS. HUAYI lead-free products meet or exceed the lead-free requirements of IPC/JEDEC J-STD-020 for MSL classification at lead-free peak reflow temperature. HUAYI defines Green to mean lead-free (RoHS compliant) and halogen free (Br or Cl does not exceed 900ppm by weight in homogeneous material and total of Br and Cl does not exceed 1500ppm by weight).

HUAYI reserves the right to make changes, corrections, enhancements, modifications, and improvements to this product and/or to this document at any time without notice.

## Absolute Maximum Ratings -

Symbol	Parameter	N- Channel	P- Channel	Unit
<b>Common Ratings</b> (Tc=25°C Unless Otherwise Noted)				
V <sub>DSS</sub>	Drain-Source Voltage	60	-60	V
V <sub>GSS</sub>	Gate-Source Voltage	±20		V
T <sub>J</sub>	Junction Temperature Range	-55 to 175		

# HYG320C06LA1S

## N-Mosfet Electrical Characteristics (T<sub>c</sub> =25°C Unless Otherwise Noted)

Symbol	Parameter	Test Conditions	HYG320C06LA1			Unit
			Min	Typ.	Max	
<b>Static Characteristics</b>						
B <sub>VDS</sub>	Drain-Source Breakdown Voltage	V <sub>GS</sub> =0V, I <sub>DS</sub> =250 A	60	-		V
I <sub>DSS</sub>	Drain-to-Source Leakage Current	V <sub>DS</sub> =60V, V <sub>GS</sub> =0V	-	-	1	A
		T <sub>J</sub> =125°C	-	-	50	A
V <sub>GS(th)</sub>	Gate Threshold Voltage	V <sub>DS</sub> =V <sub>GS</sub> , I <sub>DS</sub> =250 A	1	1.7	3	V
I <sub>GSS</sub>	Gate-Source Leakage Current	V <sub>GS</sub> =± 20V, V <sub>DS</sub> =0V	-	-	±100	nA
R <sub>DS(ON)</sub> *	Drain-Source On-State Resistance	V <sub>GS</sub> =10V, I <sub>DS</sub> =6A	-	19	26	m
		V <sub>GS</sub> =4.5V, I <sub>DS</sub> =4A		24	32	
<b>Diode Characteristics</b>						
V <sub>SD</sub> *	Diode Forward Voltage	I <sub>SD</sub> =1A, V <sub>GS</sub> =0V	-	0.7	1.0	V
t <sub>rr</sub>	Reverse Recovery Time	I <sub>SD</sub> =6A, dI <sub>SD</sub> /dt=100A/	-	12	-	ns
Q <sub>rr</sub>	Reverse Recovery Charge		-	21	-	nC

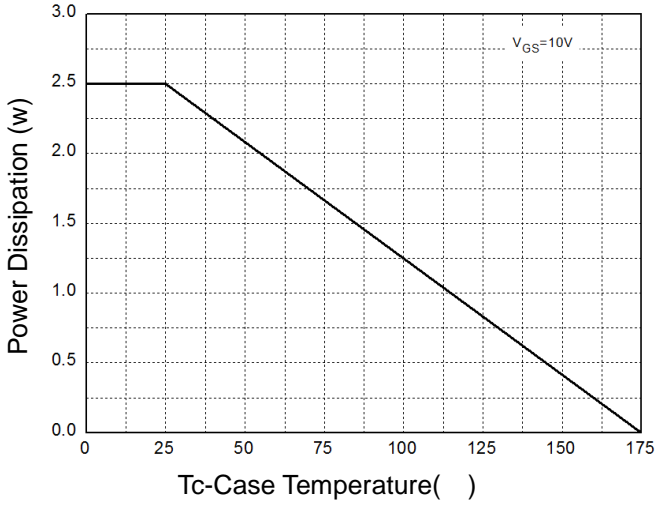
## N-Mosfet Electrical Characteristics (Cont.) (T<sub>c</sub> =25°C Unless Otherwise Noted)

Symbol	Parameter	Test Conditions	HYG320C06LA1		Unit
			Min	Typ.	

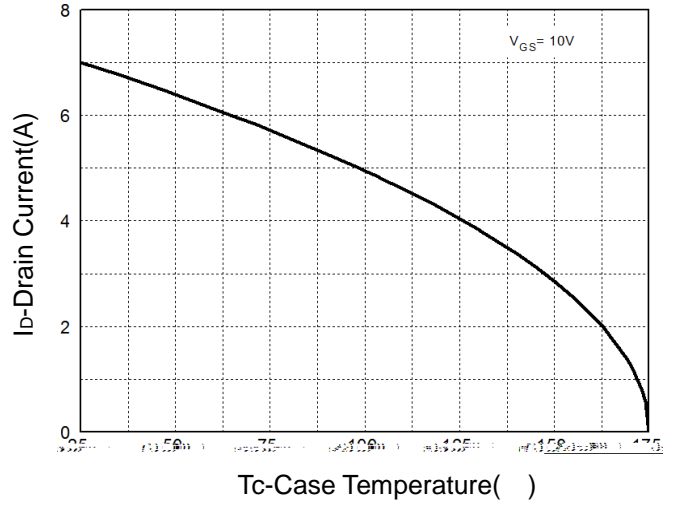
# HYG320C06LA1S

## N-Mosfet Typical Operating Characteristics

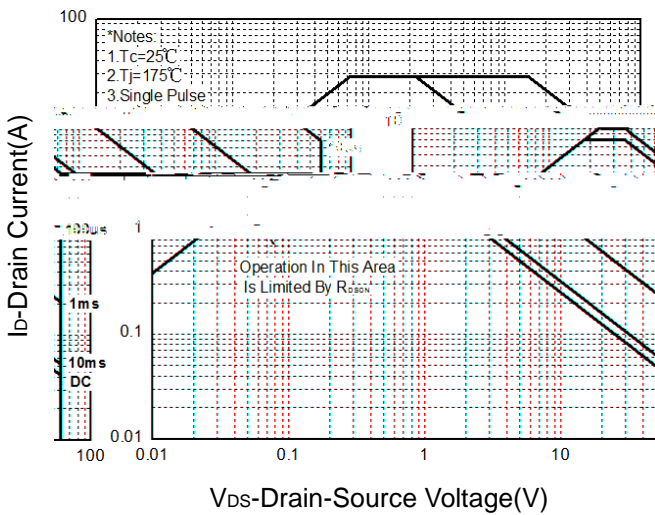
**Figure 1: Power Dissipation**



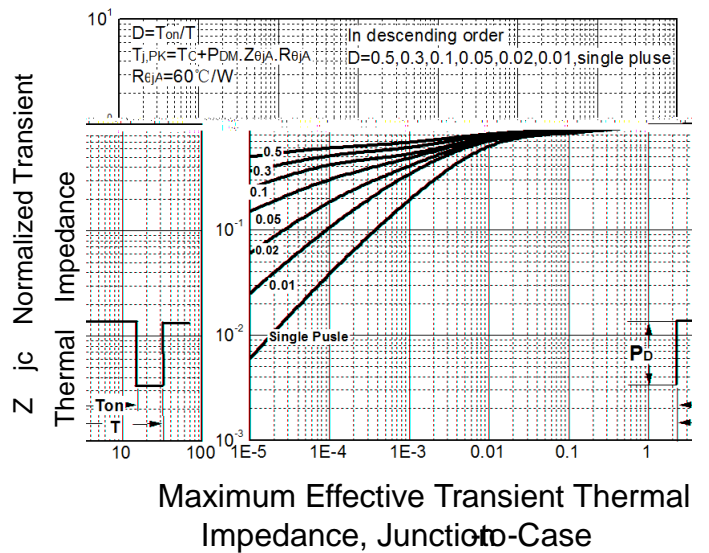
**Figure 2: Drain Current**



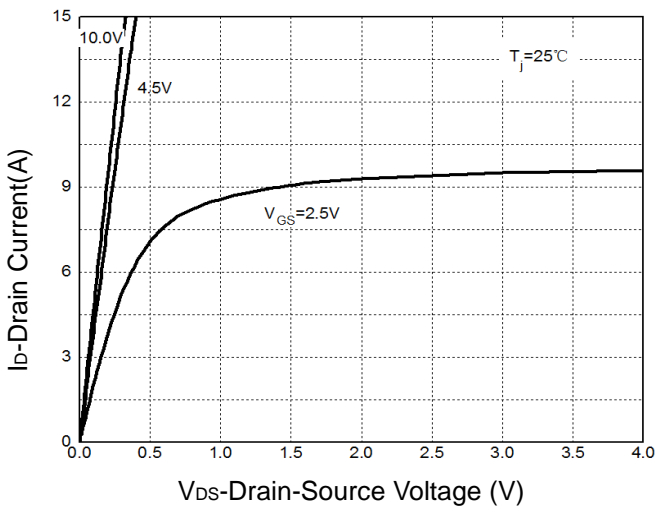
**Figure 3: Safe Operation Area**



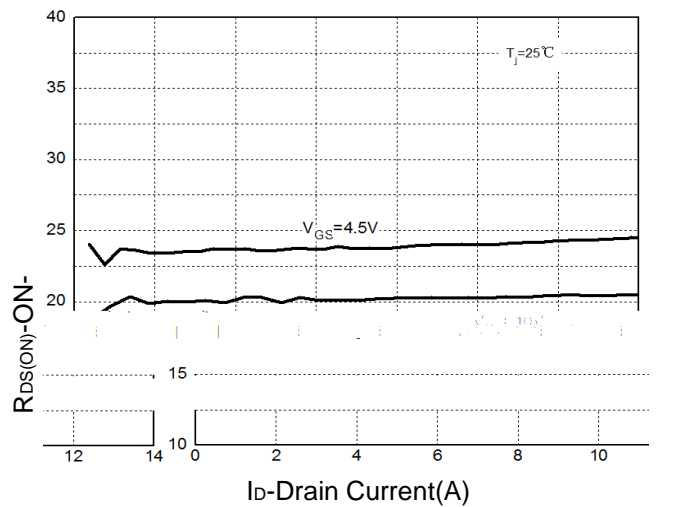
**Figure 4: Thermal Transient Impedance**



**Figure 5: Output Characteristics**

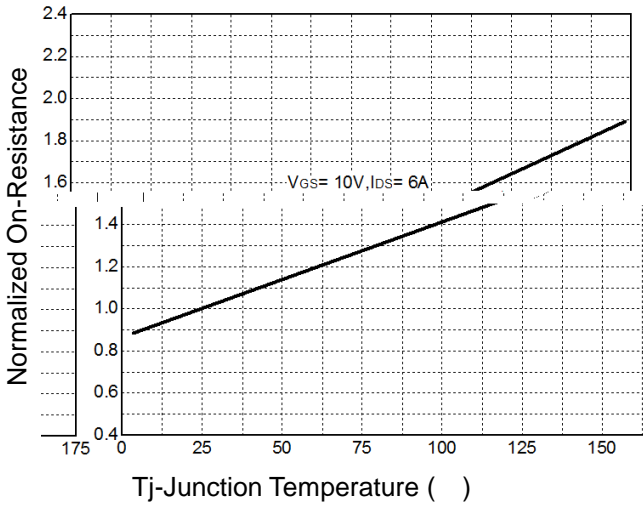


**Figure 6: Drain-Source On Resistance**

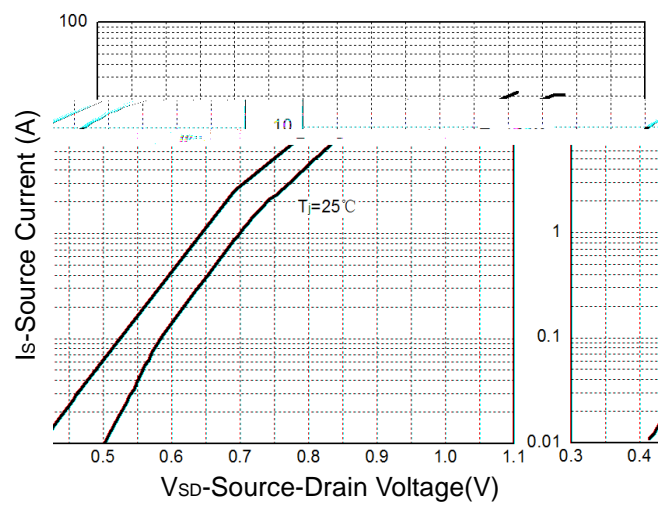


## N-Mosfet Typical Operating Characteristics

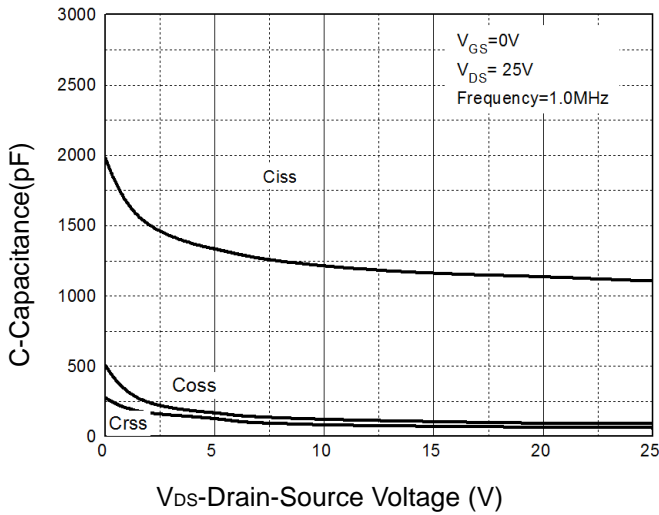
**Figure 7: On-Resistance vs. Temperature**



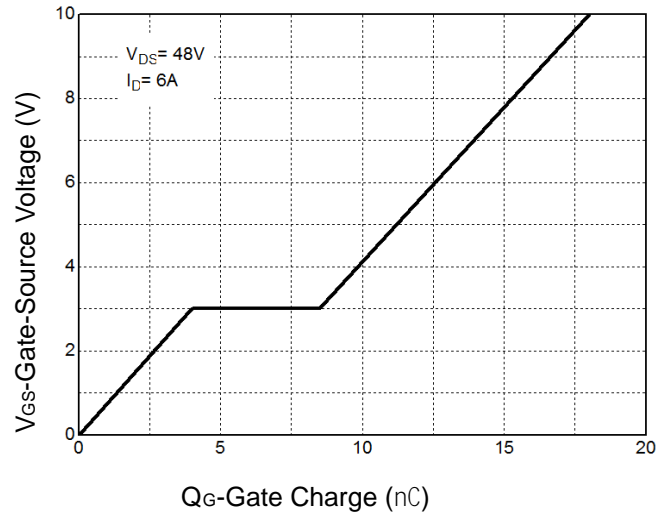
**Figure 8: Source-Drain Diode Forward**



**Figure 9: Capacitance Characteristics**

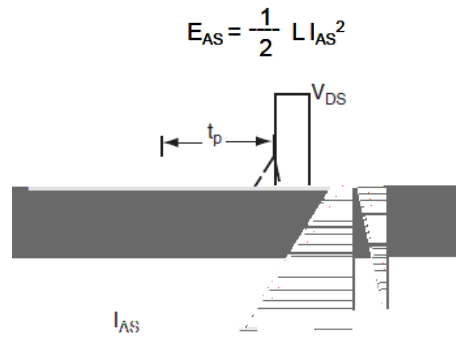
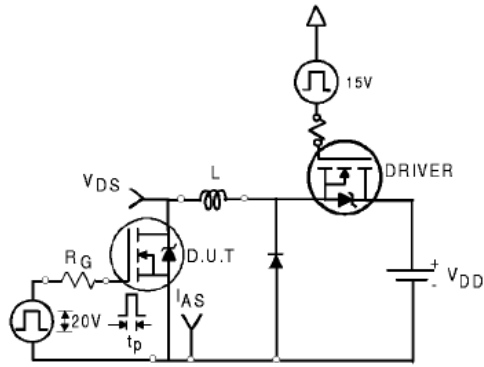


**Figure 10: Gate Charge Characteristics**

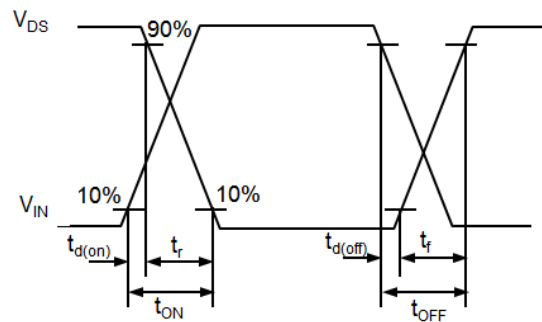
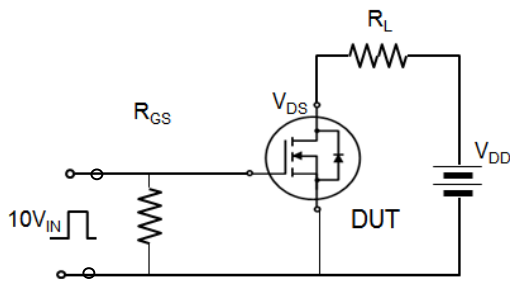


# HYG320C06LA1S

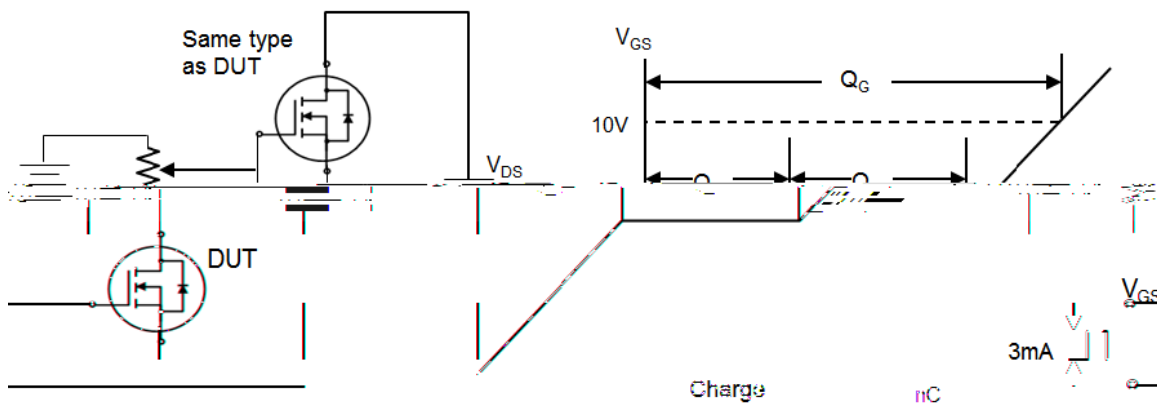
## Avalanche Test Circuit



## Switching Time Test Circuit



## Gate Charge Test Circuit



# HYG320C06LA1S



## P-Mosfet Electrical Characteristics (T<sub>c</sub> = 25°C Unless Otherwise Noted)

Symbol	Parameter	Test Conditions	Unit
--------	-----------	-----------------	------

## P-Mosfet Typical Operating Characteristics

Figure 1: Power Dissipation

Figure 2: Drain Current

Tc-Case Temperature( )

Tc-Case Temperature( )

Figure 3: Safe Operation Area

Figure 4: Thermal Transient Impedance

-V<sub>DS</sub>-Drain-Source Voltage(V)

Maximum Effective Transient Thermal Impedance, Junction-to-Case

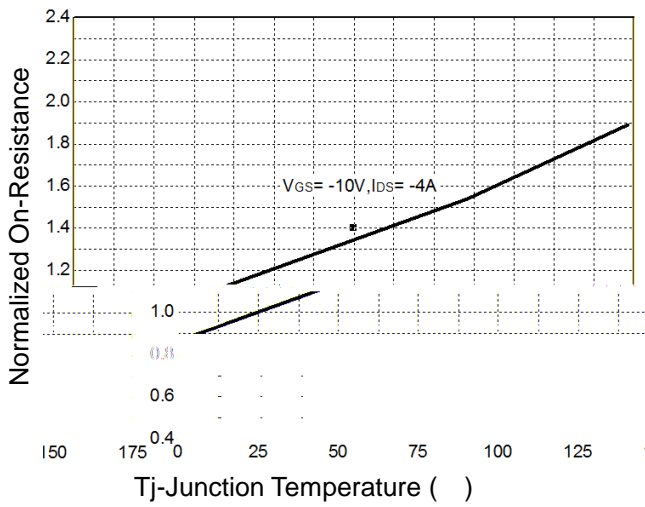
Figure 5: Output Characteristics

Figure 6: Drain-Source On Resistance

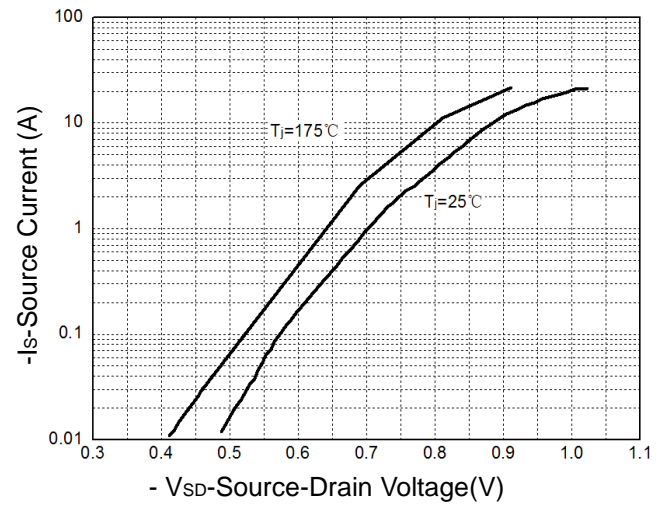


## P-Mosfet Typical Operating Characteristics

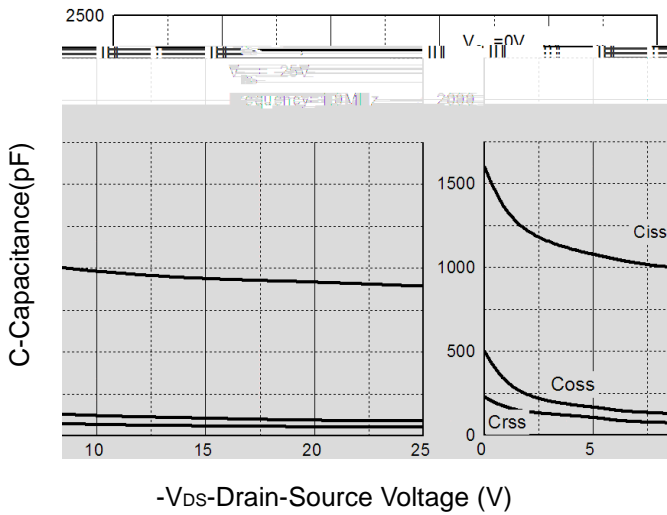
**Figure 7: On-Resistance vs. Temperature**



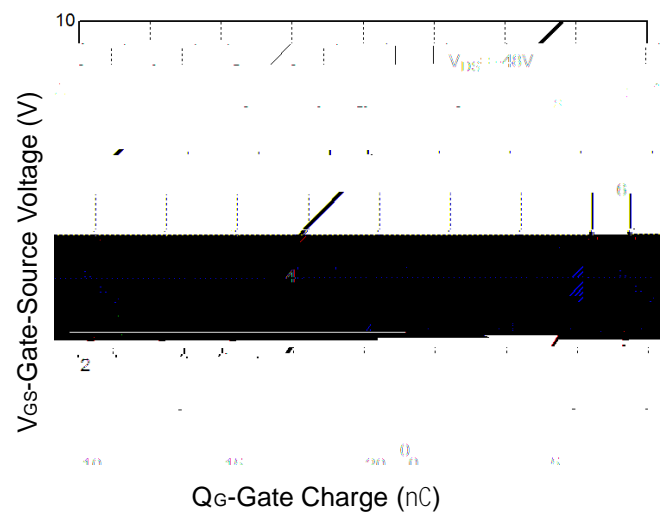
**Figure 8: Source-Drain Diode Forward**



**Figure 9: Capacitance Characteristics**

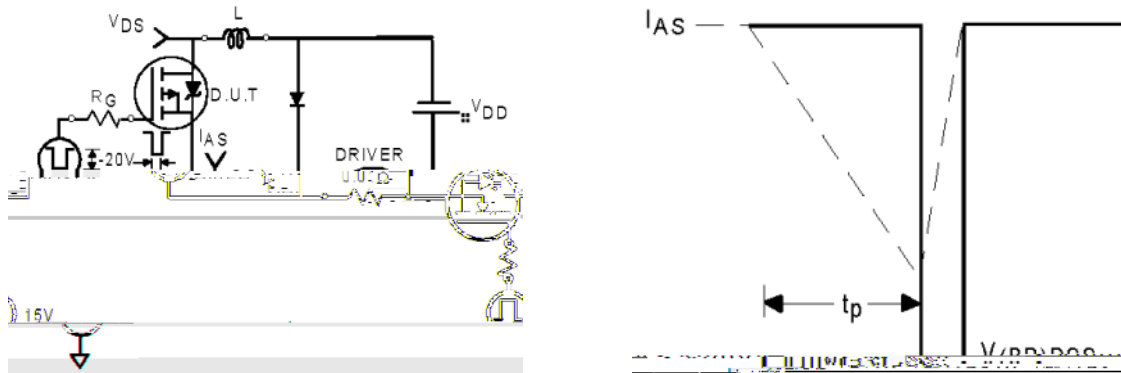


**Figure 10: Gate Charge Characteristics**

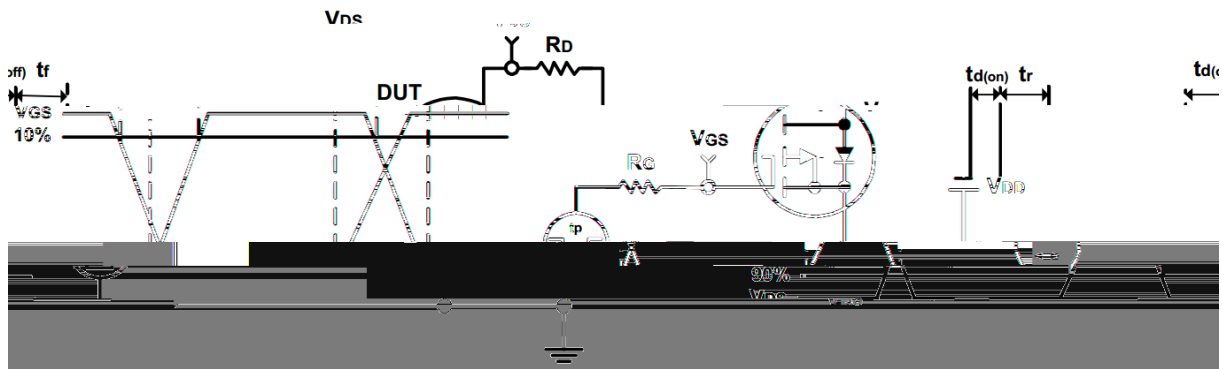


# HYG320C06LA1S

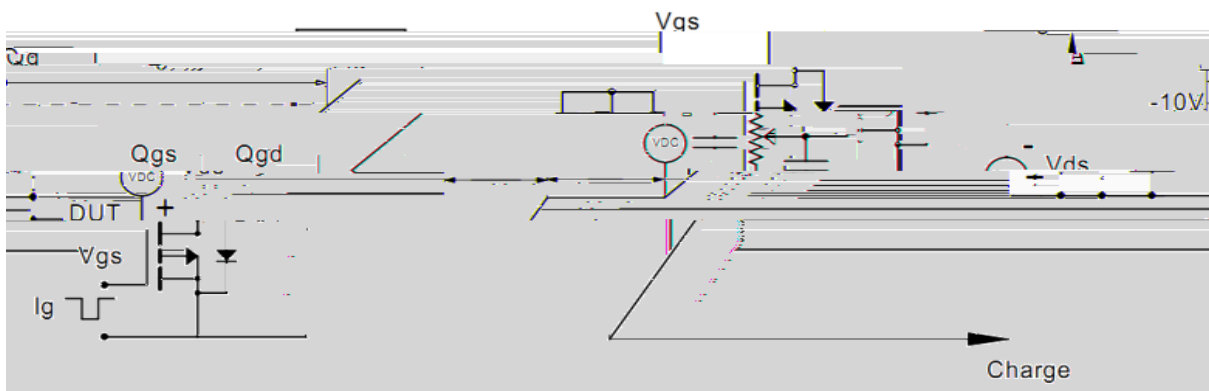
## Avalanche Test Circuit



## Switching Time Test Circuit



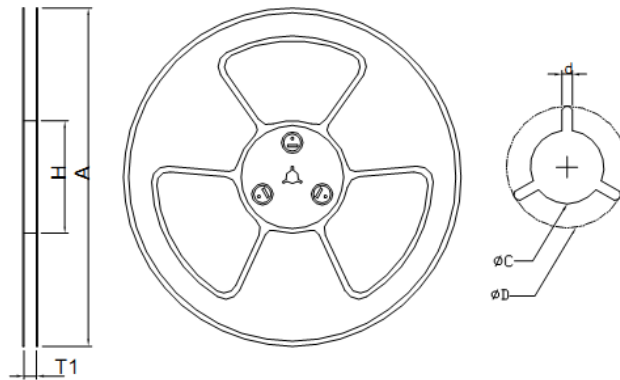
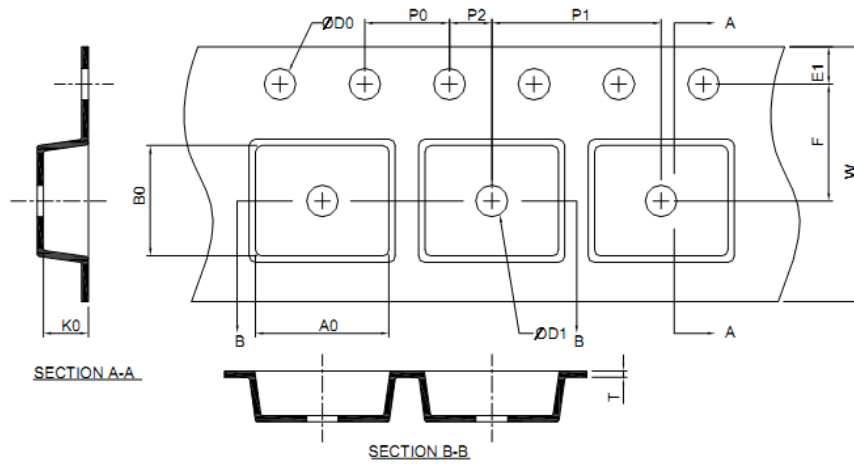
## Gate Charge Test Circuit





# HYG320C06LA1S

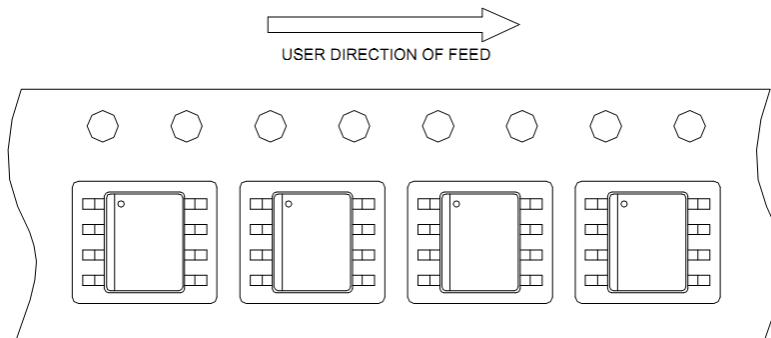
## Carrier Tape & Reel Dimensions



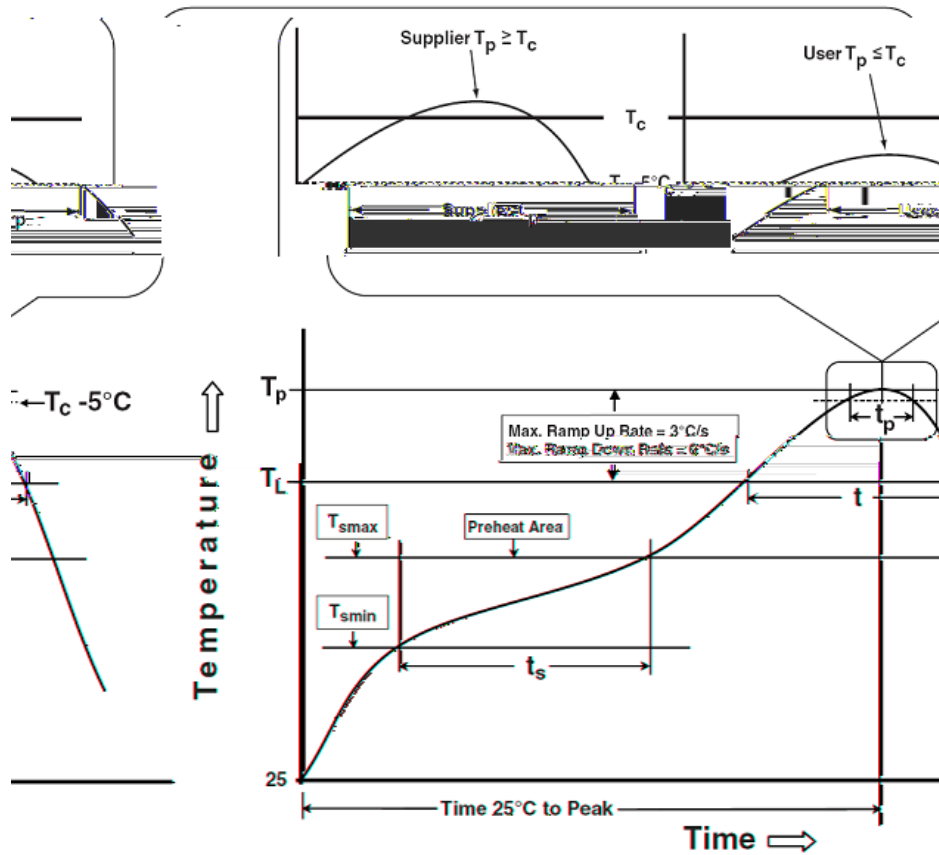
Application	A	H	T1	C	D	W	F1	F2	
SOP8L	4.0 ±0.10	8.0 ±0.10	2.0 ±0.05	1.5 <sup>+0.10</sup> <sub>-0.00</sub>	1.5 MIN.	0.6 <sup>+0.00</sup> <sub>-0.40</sub>	6.40 ±0.20	5.20 ±0.20	2.10 ±0.20

(mm)

## Taping Direction Information



## Classification Profile



## Classification Reflow Profiles

Profile Feature	Sn-Pb Eutectic Assembly	Pb-Free Assembly
<b>Preheat &amp; Soak</b>		
Temperature min ( $T_{smin}$ )	100 °C	150 °C
Temperature max ( $T_{smax}$ )	150 °C	200 °C
Time ( $T_{smin}$ to $T_{smax}$ ) ( $t_s$ )	60-120 seconds	60-120 seconds
Average ramp-up rate ( $T_{smax}$ to $T_p$ )	3 °C/second max.	3°C/second max.
Liquidous temperature ( $T_L$ )	183 °C	217 °C
Time at liquidous ( $t_L$ )	60-150 seconds	60-150 seconds
Peak package body Temperature ( $T_p$ )*	See Classification Temp in table 1	See Classification Temp in table 2
Time ( $t_p$ )** within 5°C of the specified classification temperature ( $T_c$ )	20** seconds	30** seconds
Average ramp-down rate ( $T_p$ to $T_{smax}$ )	6 °C/second max.	6 °C/second max.
Time 25°C to peak temperature	6 minutes max.	8 minutes max.
*Tolerance for peak profile Temperature ( $T_p$ ) is defined as a supplier minimum and a user maximum.		
** Tolerance for time at peak profile temperature ( $t_p$ ) is defined as a supplier minimum and a user maximum.		

Table 1.SnPb Eutectic Process Classification Temperatures (Tc)  
Package