

HY3708P/M/B/PS/PM

N-Channel Enhancement Mode MOSFET

Features

- 80V/170A
 $R_{DS(ON)} = 3.8\text{ m}\Omega$ (typ.) @ $V_{GS}=10\text{V}$
- 100% avalanche tested
- Reliable and Rugged
- Lead Free and Green Devices Available (RoHS Compliant)

Pin Description

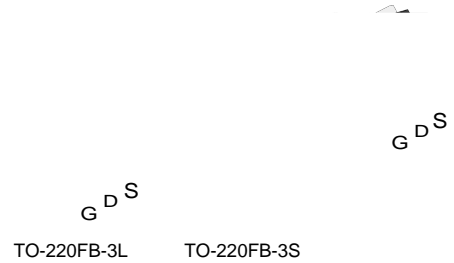

Applications



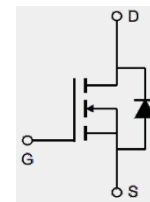

Power Management for Inverter Systems.

TO-3PS-3L TO-3PM-3S



N-Channel MOSFET

Ordering and Marking Information

 P HY3708 YYXXJWW G	 M HY3708 YYXXJWW G	 B HY3708 YYXXJWW G	Package Code P : TO-220FB-3L M : TO-220FB-3S B: TO-263-2L PS: TO-3PS-3L PM: TO-3PM-3S
 PS HY3708 YYXXJWW G	 PM HY3708 YYXXJWW G		

Note: HUAYI lead-free products contain molding compounds/die attach materials and 100% matte tin plate Termination finish; which are fully compliant with RoHS. HUAYI lead-free products meet or exceed the lead-free requirements of IPC/JEDEC J-STD-020 for MSL classification at lead-free peak reflow temperature. HUAYI defines "Green" to mean lead-free (RoHS compliant) and halogen free (Br or Cl does not exceed 900ppm by weight in homogeneous material and total of Br and Cl does not exceed 1500ppm by weight).

HUAYI reserves the right to make changes, corrections, enhancements, modifications, and improvements to this product and/or to this document at any time without notice.

Absolute Maximum Ratings

Symbol	Parameter	Rating	Unit
Common Ratings ($T_C=25^\circ\text{C}$ Unless Otherwise Noted)			
V_{DSS}	Drain-Source Voltage	80	V
V_{GSS}	Gate-Source Voltage	± 25	
T_J	Maximum Junction Temperature	175	$^\circ\text{C}$
T_{STG}	Storage Temperature Range	-55 to 175	$^\circ\text{C}$
I_S	Diode Continuous Forward Current	$T_C=25^\circ\text{C}$ 170	A
Mounted on Large Heat Sink			
I_{DM}		$T_C=25^\circ\text{C}$ 660**	A
I_D	Continuous Drain Current	$T_C=25^\circ\text{C}$ 170	A
		$T_C=100^\circ\text{C}$ 114	
P_D	Maximum Power Dissipation	$T_C=25^\circ\text{C}$ 288	
		$T_C=100^\circ\text{C}$	

1168***

HY3708

80

3.8 5.0

Electrical Characteristics (Cont.) ($T_C = 25\text{ }^\circ\text{C}$ Unless Otherwise Noted)

Symbol	Parameter	Test Conditions	HY3708			Unit
			Min.	Typ.	Max.	
Dynamic Characteristics						
R_G	Gate Resistance	$V_{GS}=0V, V_{DS}=0V, F=1\text{MHz}$	-	1.8	-	
C_{iss}	Input Capacitance	$V_{GS}=0V,$ $V_{DS}=25V,$ Frequency=1.0MHz	-	6109	-	pF
C_{oss}	Output Capacitance		-	995	-	
C_{rss}	Reverse Transfer Capacitance		-	530	-	
$t_{d(ON)}$	Turn-on Delay Time	$V_{DD}=40V, R_G=6\ \Omega,$ $I_{DS}=85A, V_{GS}=10V,$	-	28	-	ns
T_r	Turn-on Rise Time		-	18	-	
$t_{d(OFF)}$	Turn-off Delay Time		-	42	-	
T_f	Turn-off Fall Time		-	54	-	
Gate Charge Characteristics						
Q_g	Total Gate Charge	$V_{DS}=64V, V_{GS}=10V,$ $I_{DS}=85A$	-	152	-	nC
Q_{gs}	Gate-Source Charge		-	25	-	
Q_{gd}	Gate-Drain Charge		-	53	-	

Note * : Pulse test ; pulse width 300 μ s, duty cycle 2%.

Typical Operating Characteristics

Power Dissipation

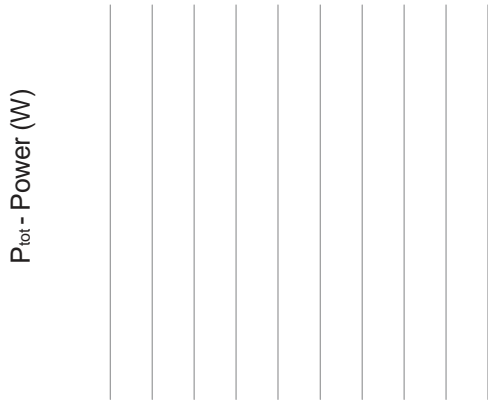

Drain Current

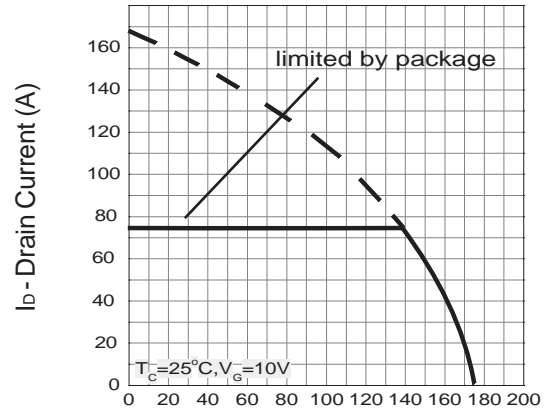

Safe Operation Area

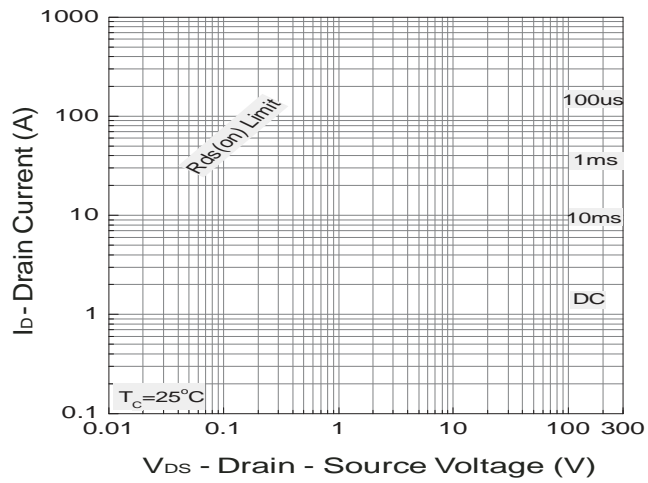

Typical Operating Characteristics (Cont.)

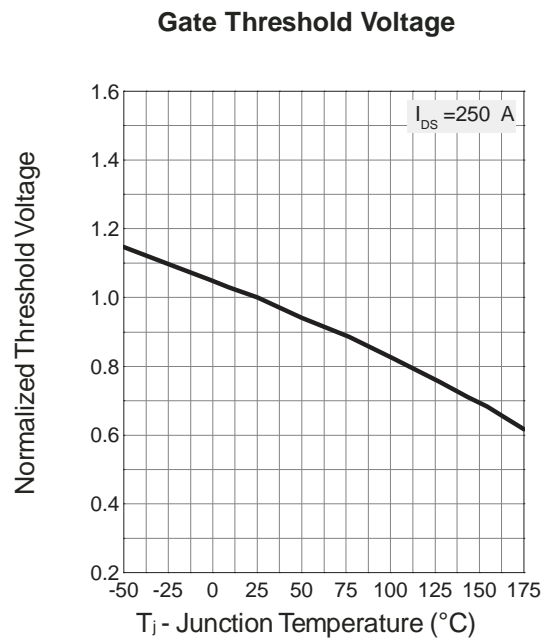
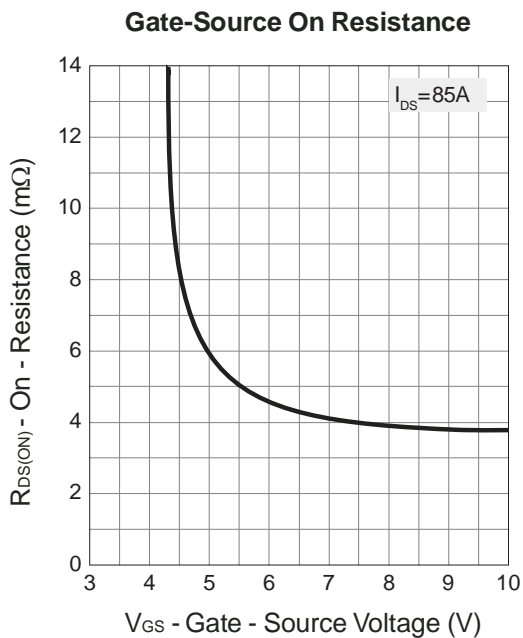
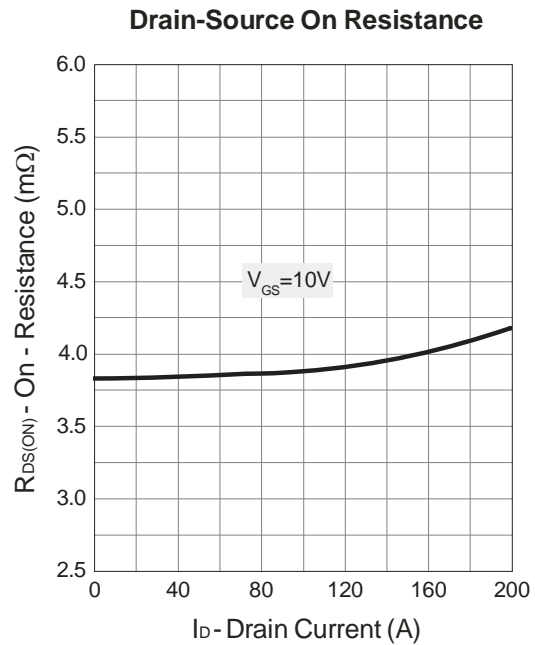
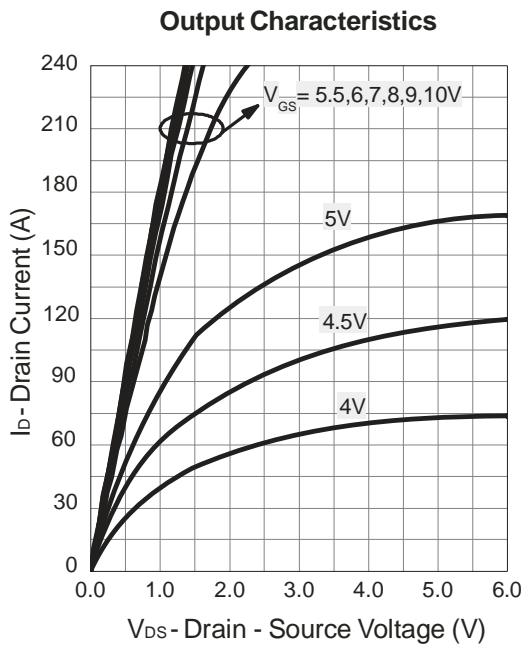

Typical Operating Characteristics (Cont.)

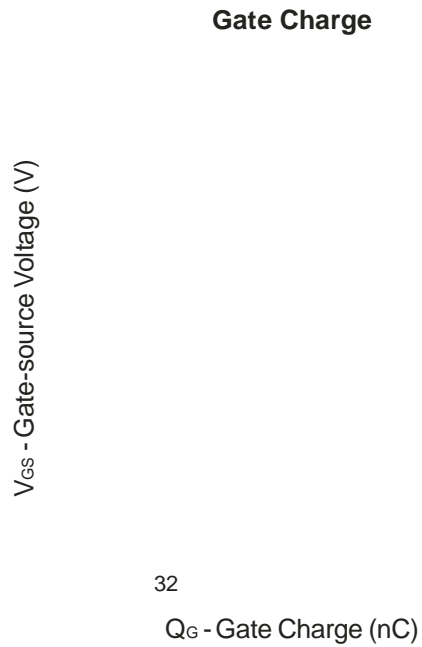
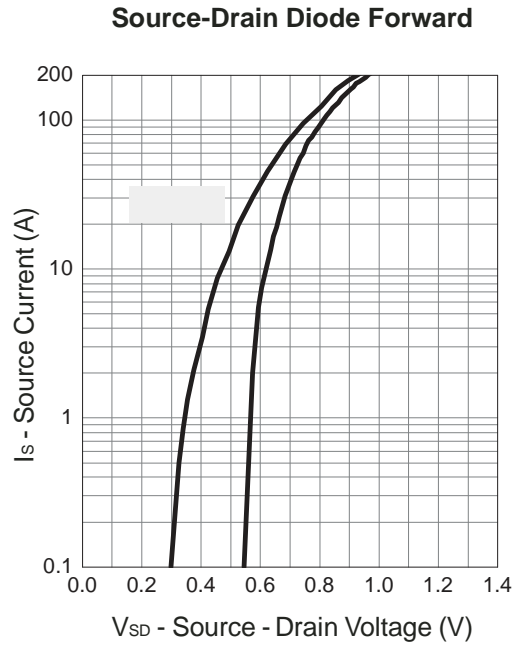
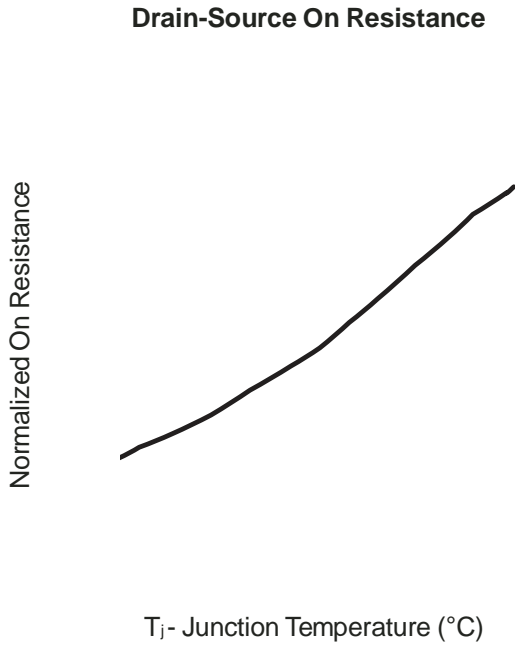

Avalanche Test Circuit

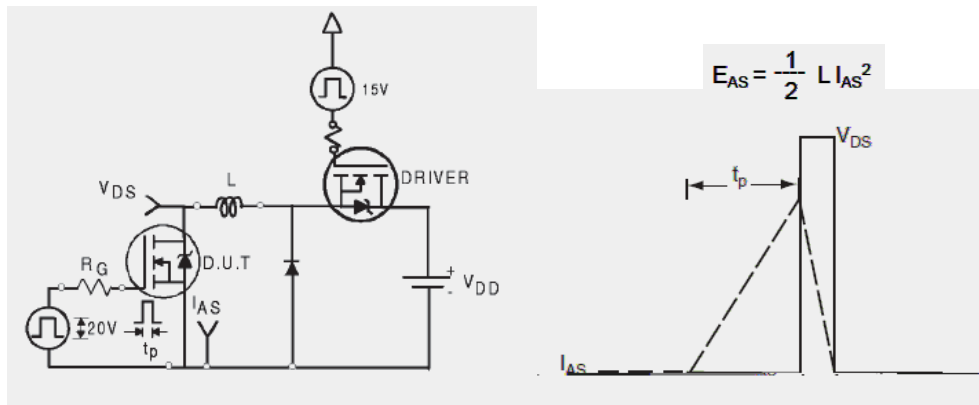

Switching Time Test Circuit

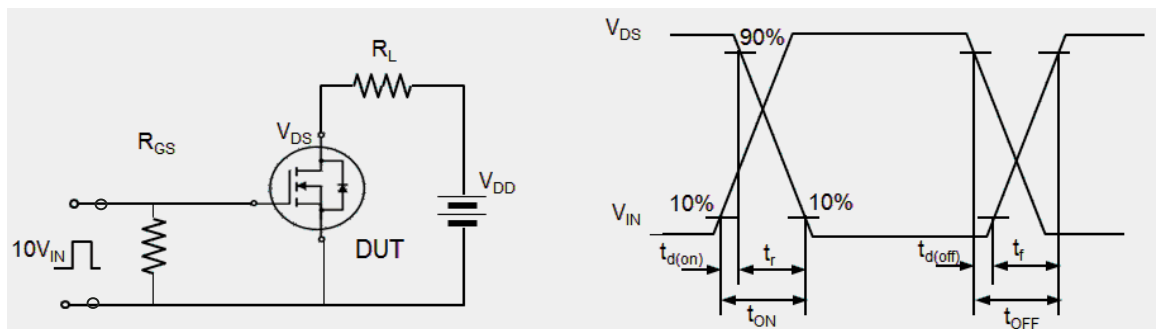

Gate Charge Test Circuit

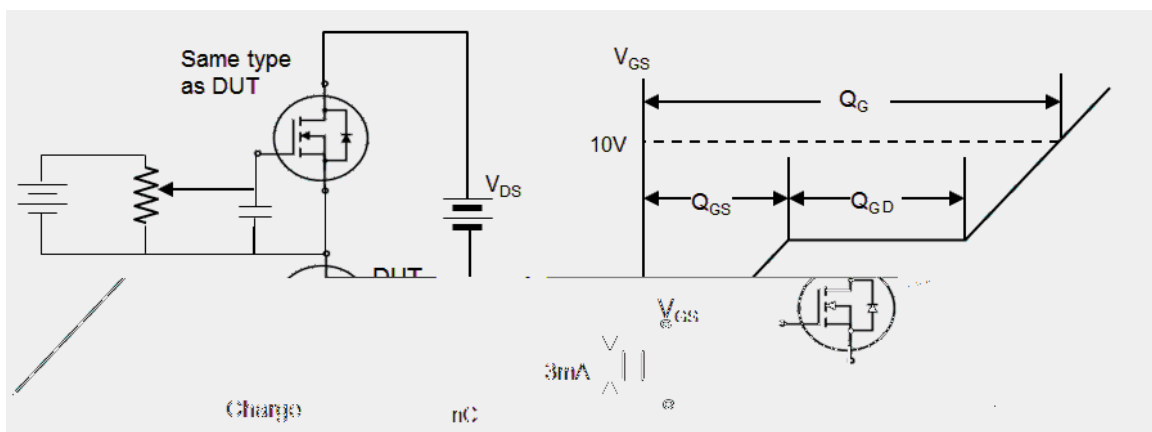

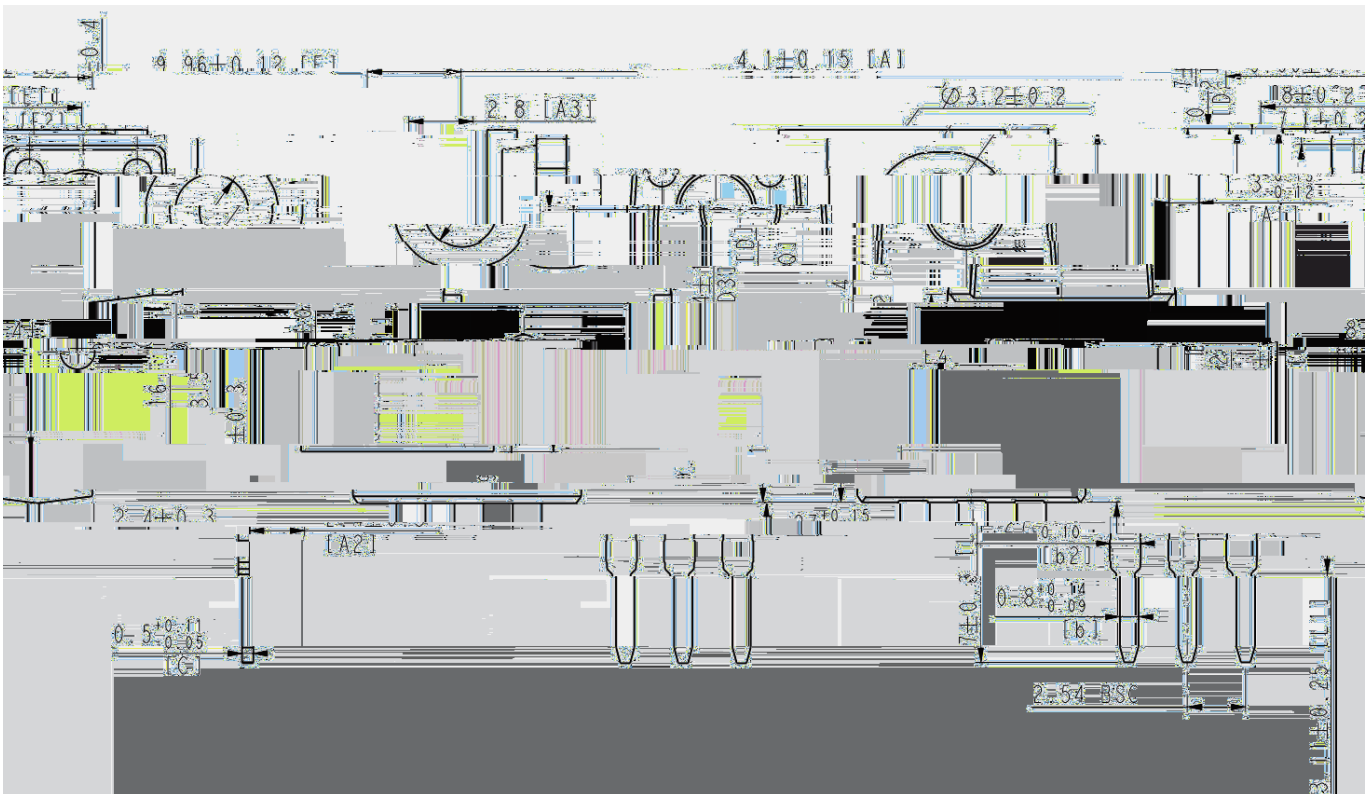

Classification Profile

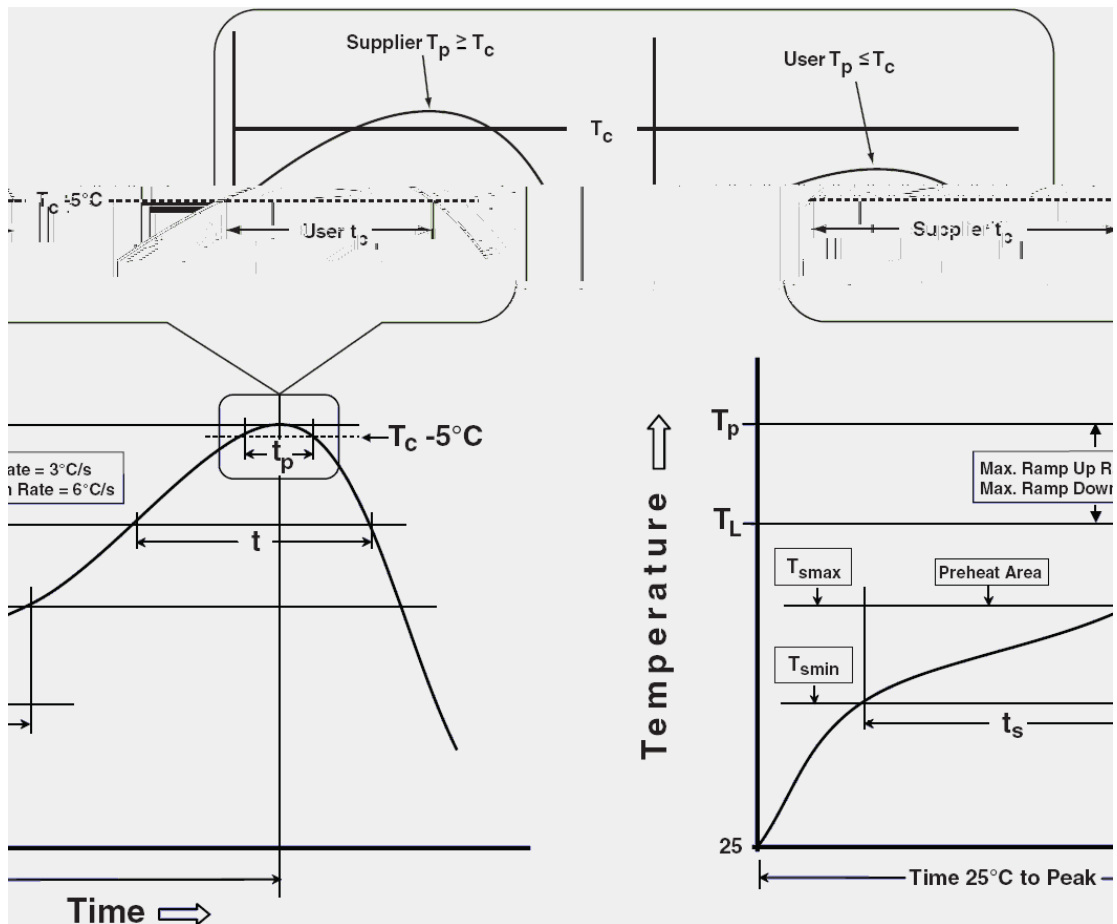

C

Profile Feature	Sn-Pb Eutectic Assembly	Pb-Free Assembly
Preheat & Soak		
Temperature min (T_{smin})	100 C	150 C
Temperature max (T_{smax})	150 C	200 C
Time (T_{smin} to T_{smax}) (t_s)	60-120 seconds	60-120 seconds
Average ramp-up rate (T_{smax} to T_p)	3 C/second max.	3 C/second max.
Liquidous temperature (T_L)	183 C	217 C
Time at liquidous (t_L)	60-150 seconds	60-150 seconds
Peak package body Temperature (T_p)*	See Classification Temp in table 1	See Classification Temp in table 2
Time (t_p)** within 5 C of the specified classification temperature (T_c)	20** seconds	30** seconds
Average ramp-down rate (T_p to T_{smax})	6 C/second max.	6 C/second max.
Time 25 C to peak temperature	6 minutes max.	8 minutes max.
* Tolerance for peak profile Temperature (T_p) is defined as a supplier minimum and a user maximum.		
** Tolerance for time at peak profile temperature (t_p) is defined as a supplier minimum and a user maximum.		

Table 1. SnPb Eutectic Process – Classification Temperatures (Tc)

Package Thickness	Volume mm ³ <350	Volume mm ³ ≥350
<2.5 mm	235 C	220 C
2.5 mm	220 C	220 C

Table 2. Pb-free Process _ Classification Temperatures (Tc)

Package Thickness	Volume mm ³ <350	Volume mm ³ 350-2000	Volume mm ³ >2000
<1.6 mm	260 C	260 C	260 C
1.6 mm – 2.5 mm	260 C	250 C	245 C
2.5 mm	250 C	245 C	245 C

Reliability Test Program

Test item	Method	Description
SOLDERABILITY	JESD-22, B102	5 Sec, 245 C
HTRB	JESD-22, A108	168 Hrs/500 Hrs/1000 Hrs, Bias @ 125 C
PCT	JESD-22, A102	96 Hrs, 100 RH, 2atm, 121 C
TCT	JESD-22, A104	500 Cycles, -55 C~150 C